

ROTARY CONTROLS

1. GENERAL FEATURES

ELESA-CLAYTON rotary controls are used to set and regulating a wide variety of machine functions.

The device consists of:

- a handwheel/knob, to manoeuvre the control spindle, thus changing the position of the machine element
- a position indicator, which provides the position of the machine element.

2. POSITION INDICATORS

ELESA-CLAYTON position indicators can be classified according to the type of reading or movement:

2.1 Types of reading

ANALOGUE: the reading is displayed by means of two rotating pointers over a graduated dial.

DIGITAL-ANALOGUE: the reading is directly displayed by means of a roller counter and a rotating pointer over a graduated dial.

DIGITAL: the reading is directly displayed by means of a roller counter.

LCD DIGITAL: the reading is directly displayed by means of a digital electronic display.

The analogue indicators are normally provided with a graduated dial and two pointers which indicate the number of turns and part of a turn made by the control spindle starting from an initial position zero. In general these indicators are used to regulate flows, capacities, strokes, setting of speed variators, etc.

The indicators with digital-analogue, digital and LCD digital reading are provided with a roller counter or a display which indicates the linear displacement of the machine element connected to the control spindle from the initial position zero.





2.2 Types of movement

GRAVITY (page 392): is used when the handwheel spindle is horizontal or max 60° inclined. The rotation of the handwheel with the indicator makes the pointers move while the dial, appropriately counterbalanced, is kept still by the gravity force.

POSITIVE DRIVE (page 398): is used on spindles in any position. The rotation of the handwheel with the indicator makes the pointers move while the dial is kept still by an anchor pin fitted to the machine.

DIRECT DRIVE (page 419): is used on control spindles in any position, the indicator is directly mounted on the control spindle and is kept in position by means of a referring back pin.

2.3 The indicators are normally supplied separately from their relative handwheels/knobs, except integral models, whose indicator is fitted in during the production.





TYPES OF READING	ANALOGUE				
TYPES OF MOVEMENT	GRAVITY			POSITIVE DRIVE	
POSITION INDICATORS SERIES	GA01 GA02 GA05	GA11 GA12	MBT.50-GA11 MBT.70-GA12	PA01 PA02 PA05	PA11 PA12
					

3. HOW TO SELECT THE ROTARY CONTROL

- 3.1 Choice of the type of reading (see 2.1). Establish if is necessary to display a number of turns or a linear displacement. For the first application choose an analogue indicator. For the second one choose a digital-analogue, digital or LCD digital indicator.
- 3.2 Establish the indicator and the spindle position on which depends the choice of the requested movement: gravity, positive drive or direct drive (see 2.2).
- 3.3 Establish the required ratio for analogue types or the reading after one revolution for the following types: digital-analogue, digital and LCD digital.
- 3.4 Establish the direction of rotation. For clockwise increasing readings (right) = D. For anticlockwise increasing readings (left) = S.
- 3.5 Consider the conditions of use of the handwheel i.e. outdoors, vibrations, corrosive environments, etc. See the complete data on the page of the chosen indicator.
- 3.6 Choose the appropriate handwheel/knob for the application considering the diameter and the grip required to transmit the necessary torque. Other factors to take into consideration are the control spindle diameter and whether a handle is required for quick operations.

4. SPECIAL EXECUTIONS

- 4.1 The ELESA-CLAYTON position indicators standard range available on this catalogue satisfies most applications. Changes to adapt the indicator to particular applications are possible, for example:
 - special dials for indicators with analogue or digital-analogue reading, on customers indications
 - stainless steel metal parts for application on machines and equipment where laws or particular hygienic and environmental factors make it mandatory to use corrosion resistant materials
 - gravity indicators with analogue reading with glycerine-filling for high vibration applications, which may interfere with the reading, or to avoid condensation on the indicator window
 - special ratio on request and for sufficient quantities, developed by ELESA Technical Department.

DIGITAL-ANALOGUE		DIGITAL		LCD DIGITAL
GRAVITY	POSITIVE DRIVE	DIRECT DRIVE		DIRECT DRIVE
GW12	PW12	DD51	DD52	DE51
				

GRAVITY INDICATORS

1. FEATURES

- 1.1 Suitable for use on control spindles with horizontal or max 60° inclined position.
- 1.2 The movement is housed in a sealed case (fig. 1). It consists of a counterweight system, fitted on a precision ballrace, which rotates on a central spindle integral with the indicator case, fitted on the handwheel/knob. At the end of the spindle there is a red pointer, which rotates with the handwheel/knob. A series of gears with different ratios transmits the rotation of the spindle to a black pointer. On the counterweight is also fixed a graduated dial. If the indicator is fitted on spindles with horizontal position (or max 60° inclined) the dial is kept still by the gravity force and the pointers rotate over it when the handwheel/knob turns.

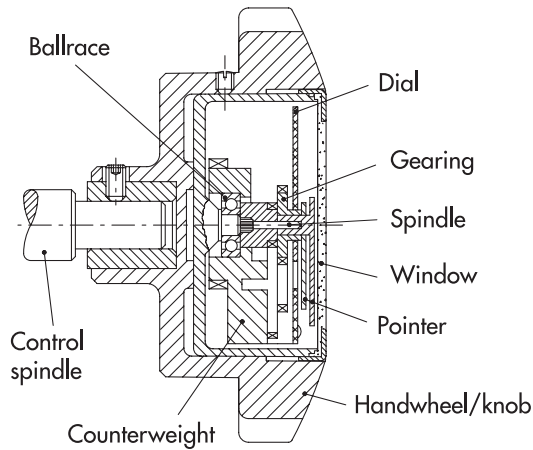

Fig.1

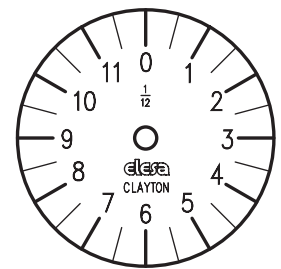

Fig.2

2. RATIOS





- 2.1 Each complete turn of the big pointer (red) corresponds to a fraction of turn of the small pointer (black). The number of turns of the red pointer to make the black pointer to carry out one complete turn is the ratio of the indicator.

Example: a ratio of 12:1 means that to 12 turns of the red pointer correspond to a complete turn of the black pointer (fig. 2).

12 turns of the handwheel cover the entire setting range. For each turn of the handwheel, the black pointer indicates 1/12 of the entire dial.

3. CHOICE OF THE INDICATOR RATIO

- 3.1 Set the control spindle to the initial or referring position.
- 3.2 Count the number of turns of the control spindle to cover the entire setting range.
- 3.3 The result of this operation is the ratio. Should it not correspond to a standard ratio, choose the next highest one.

POSSIBLE ASSEMBLY HANDWHEELS - INDICATORS						
HANDWHEELS/KNOBS		IZN.	MBT.	VHT.	VDSC+I	VDC.
INDICATORS	page	403	404	405	406	408
GA01	394	•	•	•		•
GA02	394	•	•	•	•	•
GA05	394					•
GA11	395	•	•	•		•
GA12	395	•	•	•	•	•
GW12	397	•	•	•	•	•
MBT.50/GA11	396	INTEGRAL (indicator fitted in during the production)				
MBT.70/GA12	396	INTEGRAL (indicator fitted in during the production)				

3.4 For an optimal dial reading, and therefore for a more precise reading we recommend to choose a ratio which is as near as possible to the handwheel turns required to cover the entire setting range. For instance, if 11 turns are required, the ratio 12:1 is the most convenient, because 11/12 of the available graduation will be used. If 24:1 ratio would be chosen, only 11/24 of the graduation would be used and reading would be less accurate.

3.5 Indicators with standard ratios are normally on stock to suit most requirements.

4. DIALS

4.1 Dials are available for all standard ratios in both clockwise (D) or anticlockwise (S) configurations.

4.2 Standard dials give a number which can be translated by means of conversion tables to the value of the set-up executed.

4.3 On request and for sufficient quantities special dials with marks or customised graduations can be supplied to have a direct reading.

5. ACCURACY

5.1 The gravity indicator is more accurate when used on horizontal control spindles. It can be however used on spindles max 60° inclined, but the accuracy decreases as the angle of inclination α° increases (fig. 3).

6. ASSEMBLY INSTRUCTIONS

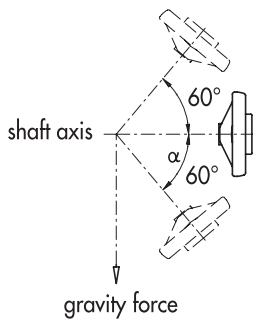

Fig.3

6.1 If the hole of the handwheel/knob hub or boss needs to be reamed for coupling to the control spindle, please refer to the handwheel/knob relevant page for further details and advice.

6.2 Assembly of the indicators to handwheels/knobs:

- couple the handwheel to the control spindle by means of a pin or a grub screw
- set the control spindle to the initial or referring position, by rotating the handwheel
- turn the indicator, by keeping it in the hands, until the pointers are in zero position
- fit the zeroed indicator into the handwheel/knob and uniformly tighten the radial securing screws with a moderate torque to prevent distortion of the indicator case and thus locking the movement.

6.3 Assembly of integral indicators (built-in in the handwheel):

- set the control spindle to the initial or referring position
- turn the indicator, by keeping it in the hands, until the pointers are in zero position
- couple the integral indicator to the control spindle by tightening the grub screw, after checking that spindle and indicator are in zero position.

Example of gravity indicator description

Series	Ratio	Clockwise graduations (Right)
G A 0 1	- 0 0 1 2	- D

VD+I 410	VRTP. 411	VR. 412	VAL. 415	VAD. 416	VAK. 418
.
.
.
.

POSITIVE DRIVE INDICATORS

1. FEATURES

- 1.1 Suitable for use on control spindles in any position.
- 1.2 The movement is housed in a sealed case (fig. 4). The handwheel/knob, containing the indicator, is coupled to the control spindle. On the rear of the handwheel/knob a flange with internal crown gear wheel (shrouded) is fitted to the machine frame by means of an anchor pin (or similar). By so doing, during handwheel rotation, the flange is integral with the machine. The rotation of the handwheel causes the planet pinion to rotate, transmitting in this way the movement inside the indicator case. The rotation is then transmitted to both pointers by means of a gearing, while the graduated dial remains still thanks to the fixing to the machine frame by means of the anchor pin.

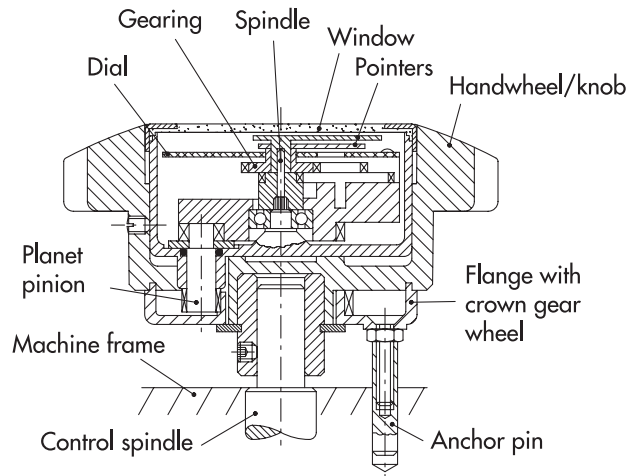

Fig.4

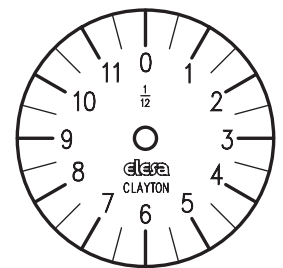



Fig.5

2. RATIOS

- 2.1 Each complete turn of the big pointer (red) corresponds to a fraction of turn of the small pointer (black). The number of turns of the red pointer to make the black pointer to carry out one complete turn is the ratio of the indicator.
Example: a ratio of 12:1 means that to 12 turns of the red pointer correspond to a complete turn of the black pointer (fig. 5).
12 turns of the handwheel cover the entire setting range.
For each turn of the handwheel, the black pointer indicates 1/12 of the entire dial.

3. CHOICE OF THE INDICATOR RATIO

- 3.1 Set the control spindle to the initial or referring position.
- 3.2 Count the number of turns of the control spindle to cover the entire setting range.
- 3.3 The result of this operation is the ratio. Should it not correspond to a standard ratio, choose the next highest one.

POSSIBLE ASSEMBLY HANDWHEELS-INDICATORS			
HANDWHEELS/KNOBS		MBT.	VHT.
INDICATORS	page	404	405
PA01	400	•	•
PA02	400	•	•
PA05	400		
PA11	401	•	•
PA12	401	•	•
PW12	402	•	•

- 3.4 For an optimal dial reading, and therefore for a more precise reading we recommend to choose a ratio which is as near as possible to the handwheel turns required to cover the entire setting range. For instance, if 11 turns are required, the ratio 12:1 is the most convenient, because 11/12 of the available graduation will be used. If 24:1 ratio would be chosen, only 11/24 of the graduation would be used and reading would be less accurate.
- 3.5 Indicators with standard ratios are normally on stock to suit most requirements.

4. DIALS





- 4.1 Dials are available for all standard ratios in both clockwise (D) or anticlockwise (S) configurations.
- 4.2 Standard dials give a number which can be translated by means of conversion tables to the value of the set-up executed.
- 4.3 On request and for sufficient quantities special dials with marks or customised graduations can be supplied to have a direct reading.

5. ASSEMBLY INSTRUCTIONS

- 5.1 Drill a bore in the machine frame for the rear anchor pin of the flange.
- 5.2 Set the control spindle to the initial or referring position.
- 5.3 Remove the black protection cap of the planet pinion, turn the latter until the pointers are in zero position.
- 5.4 Take the chosen handwheel/knob and mount the supplied anchor pin on the screw protruding from the rear flange. Be sure that the hole for the indicator planet pinion is at 12 o'clock. Turn the rear flange and position the anchor pin in line with the referring bore drilled on the machine.
- 5.5 Gently fit the zeroed indicator into the handwheel/knob, inserting the planet pinion smoothly into the corresponding hole. To make the fitting of the indicator easier, gently turn by some degrees the rear flange until the planet pinion is geared to the internal crown gear wheel. Check that the indicator is zeroed and that the screw for the anchor pin is in the correct position.
- 5.6 Uniformly tighten the lateral grub screws for fixing the indicator case with a moderate torque, to prevent distortion of the case itself and thus locking the movement.
- 5.7 Adjust the height of the anchor pin so that no undue strain is caused to the flange and tighten the locknut.
- 5.8 Couple the handwheel with the indicator to the zeroed control spindle. Be sure that the indicator pointers are in zero position and that the anchor pin is in line with the referring bore on the machine. Pin the handwheel on the spindle.
- 5.9 Check the right functioning of the indicator over all the rotation range.

Example of positive drive indicator description

Series			Ratio				Clockwise graduations (Right)		
P	A	01	-	0	0	1	2	-	D

				
EWV+IEL	VDC.	VAL.	VAD.	VAK.
407	408	415	416	418
.
.
.
.
.

Electronic spindle position indicator system

DE51 electronic direct drive absolute optical position indicators

- Up to 32 DE51 spindle position indicators for bus network connection
- Absolute multi-turn measuring system
- LCD display showing two values: target and current position

Check and quick set-up of up to 32 drive shafts

UMC100 memory and control unit

- Memory for 100 set-up profiles
- Two-line LCD display with alphanumeric characters
- Multilingual software
- 10-digit programming keyboard plus 5 function keys



• APPLICATION

The system provides an efficient electronic check of manual drive shafts with considerably lower costs than with completely automatized systems.

• EASY TO USE

The system can be used to set a number of spindles quickly (set-up profile) and in a completely guided way.

• SET-UP TIME REDUCTION

The field tests carried out on machines provided with DE51 electronic indicators, give a set-up time reduction by 30÷40% compared to those with the traditional mechanical position indicators.

• ABSOLUTE OPTICAL ENCODER

DE51 measuring system is based on an absolute optical multi-turn encoder and it is not affected by magnetic fields. Therefore it is able to guarantee perfect operation, even in the presence of electric motors. Thanks to the long-life lithium battery (more than 10 years of life-espectancy) spindle positioning variations can be registered even when the power supply is switched off and it prevents the loss of the preset values in case of an electrical power failure.

• SAFETY

The connection of DE51 electronic indicators directly to the PLC of the machine, functions also as a safety system, preventing the machine from starting to work if the set-up profile is not completed.

• RETROFIT

The small dimensions of DE51 indicators allow the retrofit of the existing machines, without any structural modifications.

